

NOTES:

1. MATERIAL:
  - 1.1 HOUSING: THERMOPLASTIC, HIGH TEMP., UL94V-0; COLOR:BLACK.
  - 1.2 CONTACT: COPPER ALLOY
  - 1.3 FITTING NAIL: COPPER ALLOY
2. FINISH:
  - 2.1 CONTACT:
    - GOLD PLATING(15u") ON CONTACT AREA.
    - GOLD FLASH PLATING ON SOLDER TAILS,
    - 50u" MIN. NICKEL UNDERPLATING OVERALL.
  - 2.2 FITTING NAIL:
    - 100u" TIN PLATING ON SOLDER TAILS.
    - 50u" MIN. NICKEL UNDERPLATING OVERALL.
3. REFLOW SOLDER CAPABLE TO 260°C PER ACES SPEC.
4. SPEC. PLS. REFER TO PS-50981-xxxxx
5. PACKAGE PLS. REFER TO 50981-xxxxx-TRP

6. PART NUMBER

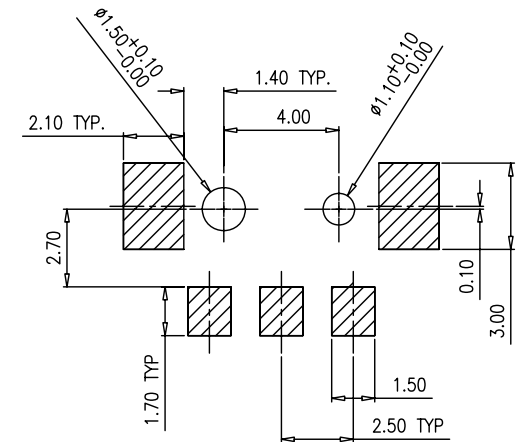
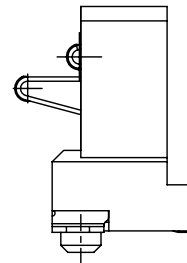
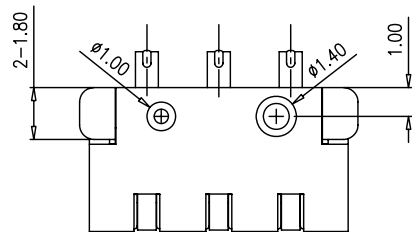
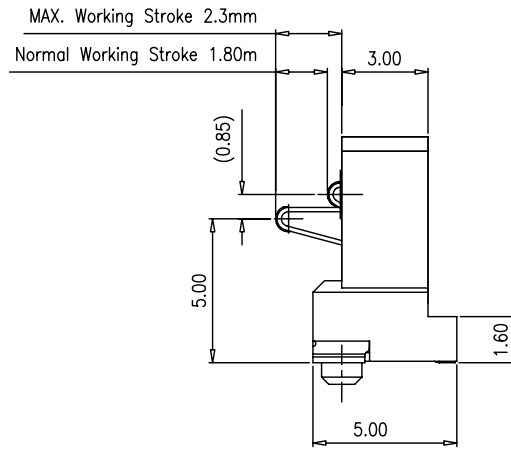
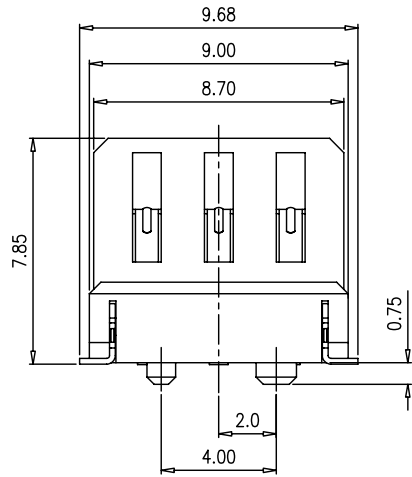
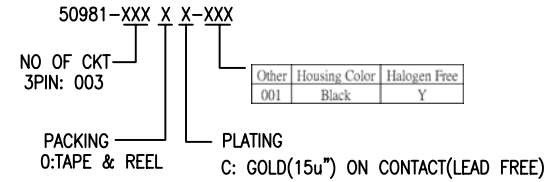

RECOMMENDED PCB LAYOUT  
TOLERANCE ±0.05

一般公差 <b>TOLERANCES</b> X ±0.5    XX ±0.15 X ±0.25    XXX ±0.1 ANGLES    ±2°		<b>宏致電子股份有限公司</b> <b>Aces Electronic Co.,Ltd.</b>	
檢驗尺寸標示 <b>SYMBOLS</b> Ⓞ Ⓢ INDICATE CLASSIFICATION DIMENSION Ⓞ MARK IS CRITICAL DIM. Ⓢ MARK IS MAJOR DIM.		品名 (TITLE) 2.50mm BATTERY CONN. SMT R/A H=7.85mm 3P	
表面處理 (FINISH)		圖號 (DWG.NO) 50981-XXXXX-XXX	
比例 (SCALE) 單位 (UNITS)		製圖 (DR) '08/10/09 CARL 審核 (CHKD) WARLES 核准 (APPD) JASON	
1 OF 1		張數 (SHEET) 1 OF 1 尺寸 (SIZE) A4 版數 (REV) 0	

0	FOR APD970339 ■ RELEASE,ECN-0903028	'09/03/04	CARL
REV	REVISION DESCRIPTION	DATE	申請人 SIGNATURE